

STATIC torque transducer

Series -CPRX

Réf : F FP 3509

Rev :



DESCRIPTION

Torque meter has been designed to perform torque measurements both in clockwise and anticlockwise direction with a high precision.

Main fields of application vary from the industrial one on test benches and materials test machines to the most strictly metrological sectors such as first line samples for test and calibration laboratories, research bodies etc.

Used also as transfer samples for evaluating the uncertainty of direct weights test benches or for comparison among the different reference National Institutes.

Manufactured in two main accuracy classes 0.05 or 0.1 according to EURAMET cg-14 norm with a yearly drift lower than 0.003%

Measurement stability is ensured even in wet and hard environments thanks to a high protection grade realized though LASER welding which guarantee the tightness.

The monolithic body, entirely made in stainless steel, guarantees a high resistance to dynamic stress which can occur in both measurement directions.

Torque meter is manufactured in 3 specific structures in order to cover a very wide range up to 5000 Nm.

ELECTRICAL CONNECTIONS

TRANSDUCERS	OUTPUT	CABLE
	EXCITATION+ SENSE+ OUTPUT+ EXCITATION - SENSE- OUTPUT- -----	Red Orange White Black Blue Yellow Shield*

TECHNICAL DATA

Accuracy class: EURAMET cg-14	0.05		0.1
STATIC NOMINAL TORQUE	50 – 100 N·m 200 – 500 N·m 1 - 2 - 3 - 5 kN·m		
RELATIVE ERROR (at reading)			
a) repeatability 0°-120°-240° (b)	$\leq \pm 0.050\%(1)$		$\leq \pm 0.100\%(1)$
b) interpolation (fa)	$\leq \pm 0.025\%(1)$		$\leq \pm 0.050\%(1)$
c) hysteresis (h)	$\leq \pm 0.063\%(1)$		$\leq \pm 0.125\%(1)$
d) zero (fo)	$\leq \pm 0.012\% \text{ F.S.}$		$\leq \pm 0.025\% \text{ F.S.}$
LINEARITY	$\leq \pm 0.03\% \text{ F.S.}$		
HYSTERESIS	$\leq \pm 0.03\% \text{ F.S.}$		
TEMPERATURE EFFECT (10°C)			
a) on zero	$\leq \pm 0.020\%$		
b) on sensitivity	$\leq \pm 0.010\%$		
NOMINAL SENSITIVITY	1 mV/V		
SENSIVITY TOLERANCE	$\leq \pm 0.1\% \text{ F.S.}$		
INPUT RESISTANCE	700±2Ω		
OUTPUT RESISTANCE	705±2Ω		
INSULATION RESISTANCE	> 5 GΩ		
ZERO BALANCE	$\leq \pm 0.5\% \text{ F.S.}$		
RECOMMENDED SUPPLY VOLTAGE	10 V		
NOMINAL SUPPLY VOLTAGE RANGE	1-15 V		
MAXIMUM SUPPLY VOLTAGE	18 V		
MECHANICAL LIMIT VALUES:			
a) service load	120% F.S.		
b) max permissible load	150% F.S.		
c) breaking load	>300% F.S.		
d) max transverse load	50% F.S.		
e) max permissible dynamic load	75% F.S.		
REFERENCE TEMPERATURE	+23°C		
TEMPERATURE NOMINAL RANGE	0/+60 °C		
SERVICE TEMPERATURE RANGE	-10/+70 °C		
STORAGE TEMPERATURE RANGE	-20/+80 °C		
PROTECTION CLASS (EN 60529)	IP67		
EXECUTION MATERIAL	Acier inoxydable		
CABLE LENGTH	5m		
TEMPÉRATURE DE RÉFÉRENCE	+23 °C		
TEMPÉRATURE DE TRAVAIL	-10 / +70 °C		
TEMPÉRATURE DE STOCKAGE	-20 / +80 °C		
COUPLE NOMINAL	50 N·m 100 N·m	De 200 N·m à 2kN·m	3 kN·m 5 kN·m
WEIGHT	~ 1.5 kg	~ 3 kg	~ 4.5 kg
FIXING SCREWS			
a) diameter	M8	M12	M16
b) resistance class	12.9	12.9	12.9
c) tightening torque	40 N·m	140 N·m	368 N·m

DIMENSIONS

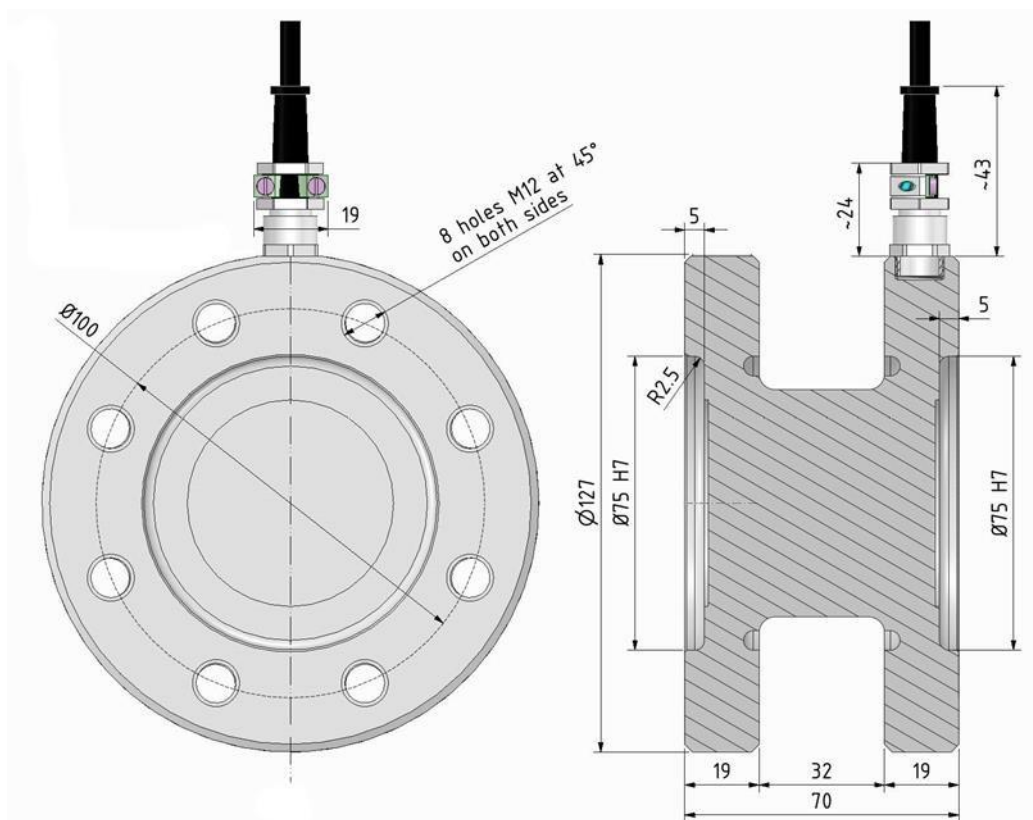
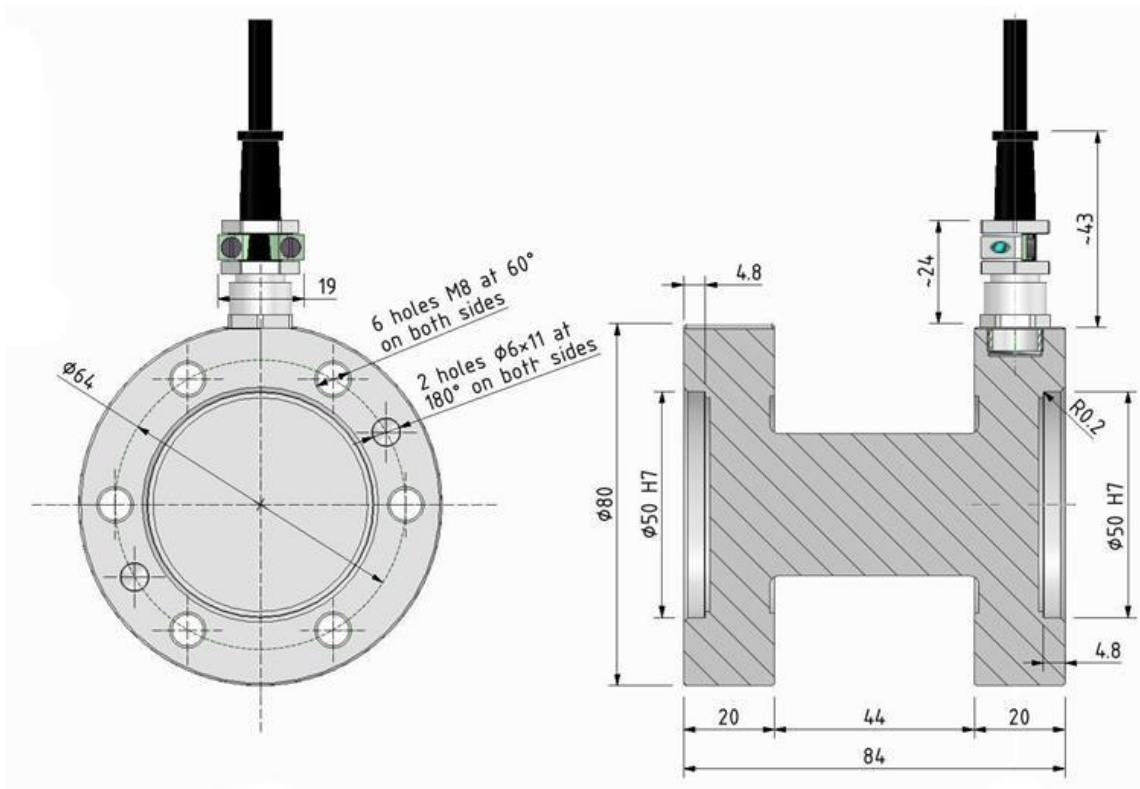

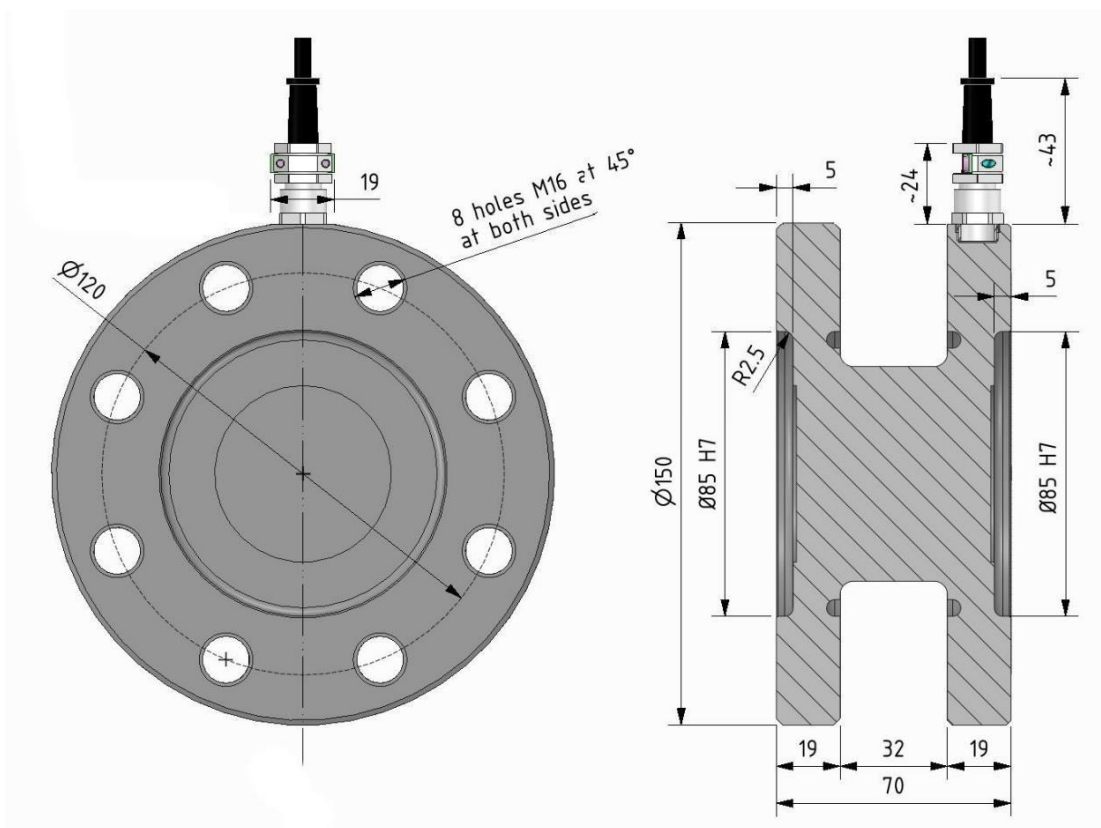

CONTACT

MESUREX

13 Rue des Corroyés
78730 Saint Arnoult en Yvelines

Tel : +33 (0) 1 30 41 23 62
Fax : +33 (0) 1 30 41 23 80
Mail : mesurex@mesurex.fr